



FORMATURA
INIEZIONE
POLIMERI

VKD/CP DN 65-100



Dual Block®

avrorarm.ru
+7 (495) 956-62-18

Dual Block ®

FIP

Dual Block ®,
VKD

- d65 d110 R 2½" R4"
- :
- ,
- 16 20° ,
- DUAL BLOCK®:
- ,
- SEAT-STOP,
-
-
- FIP,
-
- NAMUR.
- VDI/VDE 3845

FIP

FIP

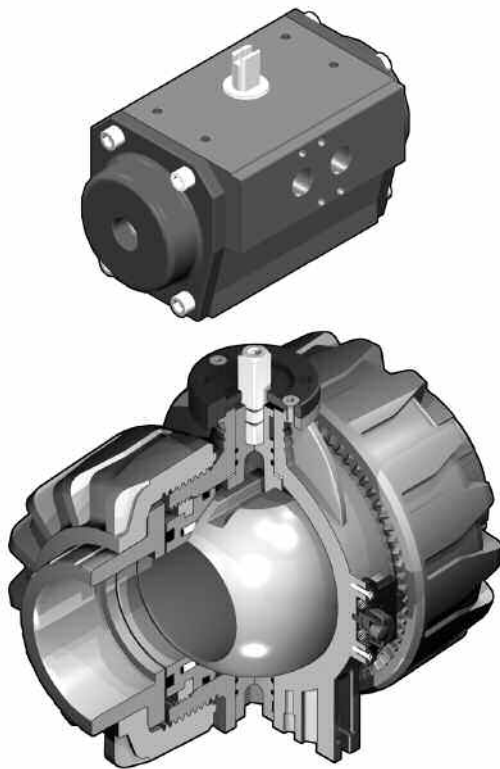

d	()	
DN	()	
R		
PN		
	,	20°
g		
U		
s	()	
SDR	d/s	
U-PVC		
PP-H		
PVC-C		
PVDF	()	
EPDM	-	-
FPM		
PTFE		
PE		
DA		
SA		
POM		

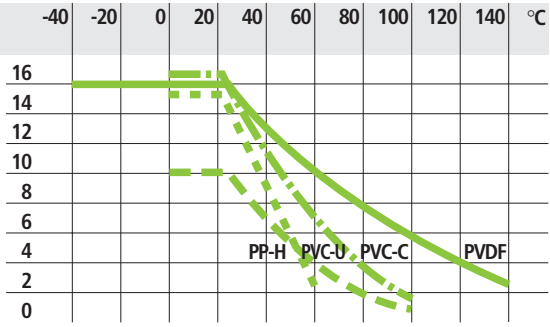
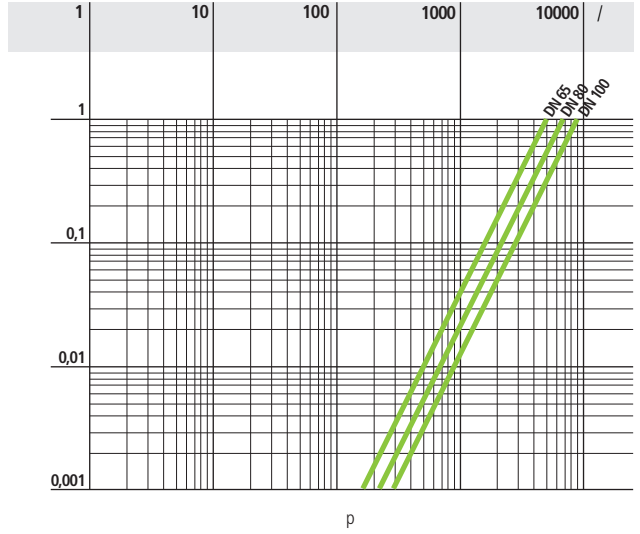
1

2

3

d	75	90	110
DN	65	80	100
k_{v100}	5250	7100	9500

1

(25)

2
3

$k_{v100} - \Delta p = 1$ / 20°

FIP

- U-PVC: ISO727, EN 1452, DIN 8063, BS4346/1, ASTM 2467/76a.
ISO161/1, EN 1452, DIN 8062, NF T54-016, BS3506,
BS3505, ASTM 1785/76.
- PVC-C: ISO727, EN ISO 15493, ASTM F439.
EN ISO 15493, DIN 8079/8080, ASTM D 1785/76.
- PP-H: DIN 16962
: ISO 3609, DIN 8077, UNI 8318, BS 4991.
- PVDF: ISO DIS 10931
: ISO DIS 10931/2
: UNI-ISO 228/1, DIN 2999, BS21, ASA ANSI B1.20 1
: ISO 2084, EN 1452, DIN 8063, ASA ANSI B.16.5 150.

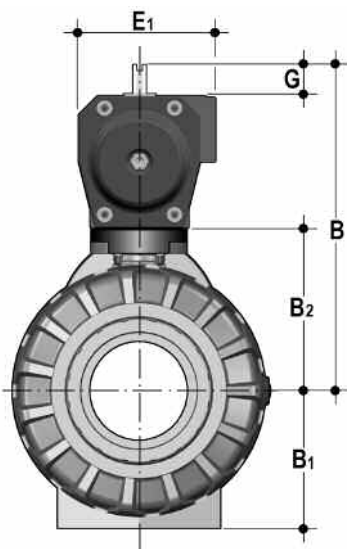

DN	B ₁	B ₂	B		E ₁		G	g PVC		g PP-H		g PVC-C		g PVDF	
			(DA)	(SA)	(DA)	(SA)		(DA)	(SA)	(DA)	(SA)	(DA)	(SA)		
65	87	119	222	239	86	94	30	5400	7170	4110	5880	5770	7540	6673	8443
80	105	132	252	262	94	104	30	9520	11450	7400	9330	10158	12088	11910	13840
100	129	150	280	295	104	120	30	14660	17280	11245	13865	15657	18277	18170	20790

VKDIV/CP VKDIM/CP VKDIC/CP VKDIF/CP

DUAL BLOCK

ISO

U-PVC, PP-H, PVC-C, PVDF

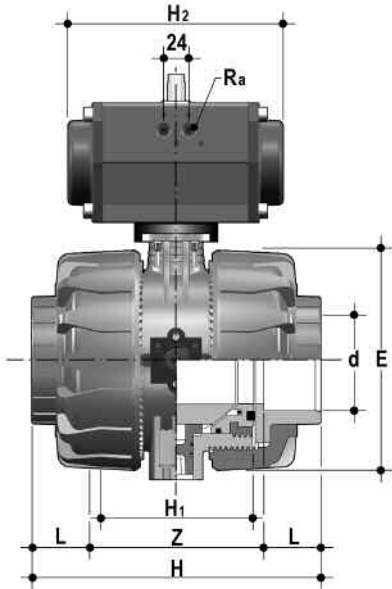

d	DN	*PN	Z	L		H		H ₁	E	H ₂		Ra
				PVC-U PVC-C	PP-H PVDF	PVC-U PVC-C	PP-H PVDF			(DA)	(SA)	
75	65	16	147	44	33	235	213	133	164	155	210	G1/4"
90	80	16	168	51	36	270	239	149	203	210	228	G1/4"
110	100	16	186	61	41	308	268	167	238	228	280,5	G1/4"

* PP-H PN 10 bar

VKDDV/CP VKDDM/CP VKDDC/CP VKDDF/CP

DUAL BLOCK

ISO

U-PVC, PP-H, PVC-C, PVDF

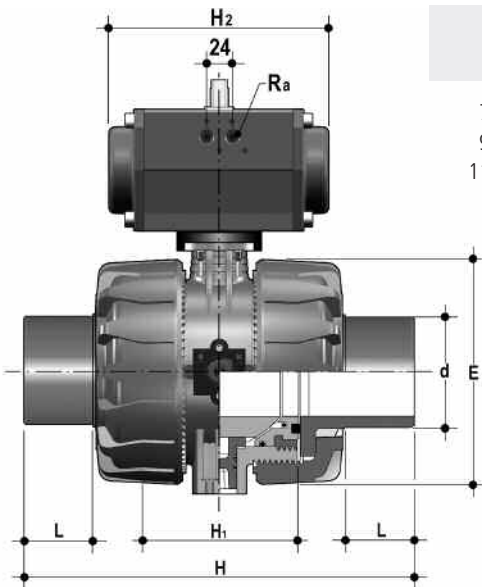

d	DN	*PN	L		H	H ₁	E	H ₂		H ₃
			PVC-U PVC-C	PP-H PVDF				(DA)	(SA)	
75	65	16	44	36,5	284	133	164	155	210	G1/4"
90	80	16	51	37,5	300	149	203	210	228	G1/4"
110	100	16	61	42,5	340	167	238	228	280,5	G1/4"

* PP-H PN 10 bar

VKDLV/CP

DUAL BLOCK

BS

U-PVC

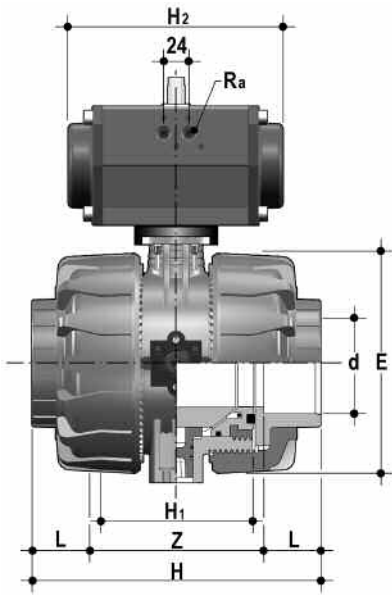

d	DN	PN	Z	L	H	H ₁	E	H ₂		Ra
								(DA)	(SA)	
2" 1/2	65	16	147	44	235	133	164	155	210	G1/4"
3"	80	16	168	51	270	149	203	210	228	G1/4"
4"	100	16	186	63	308	167	238	228	280,5	G1/4"

VKDFV/CP

DUAL BLOCK

BS

U-PVC

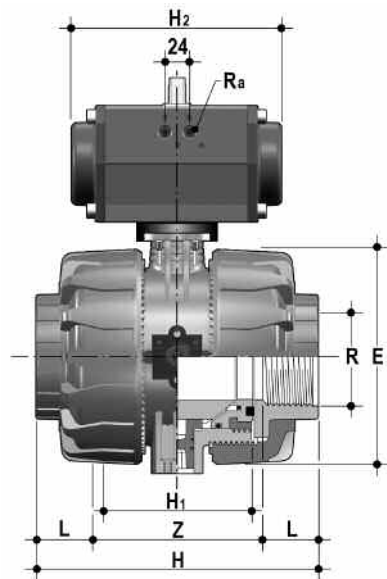

d	DN	PN	Z	L	H	H ₁	E	H ₂		Ra
								(DA)	(SA)	
2" 1/2	65	16	168,6	33,2	235	133	164	155	210	G1/4"
3"	80	16	199	35,5	270	149	203	210	228	G1/4"
4"	100	16	232,8	37,6	308	167	238	228	280,5	G1/4"

VKDAV/CP VKDAC/CP

DUAL BLOCK

ASTM

U-PVC, PVC-C

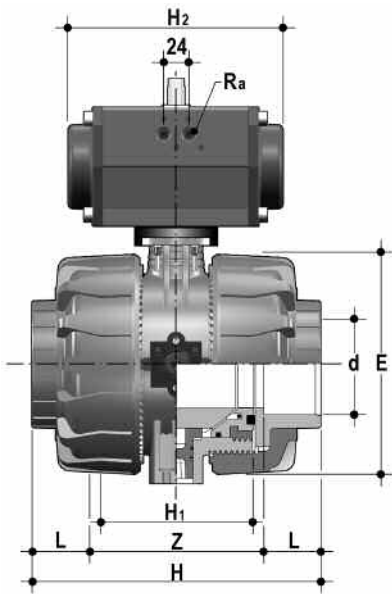

d	DN	PN	Z	L	H	H ₁	E	H ₂		Ra
								(DA)	(SA)	
2" 1/2	65	16	146	44,5	235	133	164	155	210	G1/4"
3"	80	16	174	48	270	149	203	210	228	G1/4"
4"	100	16	193	57,5	308	167	238	228	280,5	G1/4"

VKDFV/CP NPT VKDFC/CP NPT

DUAL BLOCK

NPT

U-PVC, PP-H

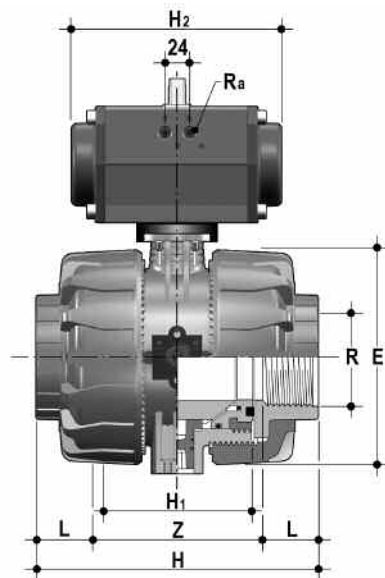

d	DN	PN	Z	L	H	H ₁	E	H ₂		Ra
								(DA)	(SA)	
2" 1/2	65	16	168,6	33,2	235	133	164	155	210	G1/4"
3"	80	16	199	35,5	270	149	203	210	228	G1/4"
4"	100	16	232,8	37,6	308	167	238	228	280,5	G1/4"

* PP-H PN 10 bar

VKDJV/CP

DUAL BLOCK

JIS

U-PVC

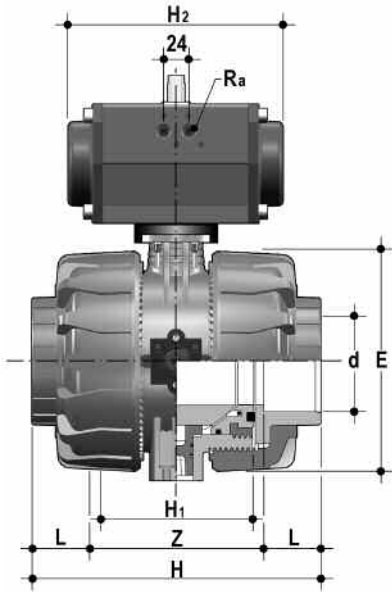

d	DN	PN	Z	L	H	H ₁	E	H ₂		Ra
								(DA)	(SA)	
2" 1/2	65	16	145	61	267	133	164	155	210	G1/4"
3"	80	16	165	65	294	149	203	210	228	G1/4"
4"	100	16	202	84	370	167	238	228	280,5	G1/4"

VKDG/CP

DUAL BLOCK

JIS

U-PVC

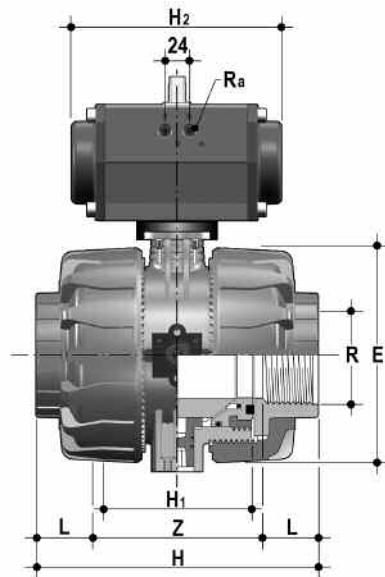

d	DN	PN	Z	L	H	H ₁	E	H ₂		Ra
								(DA)	(SA)	
2" 1/2	65	16	165	35	235	133	164	155	210	G1/4"
3"	80	16	190	40	270	149	203	210	228	G1/4"
4"	100	16	218	45	308	167	238	228	280,5	G1/4"

VKDOV/CP VKDOM/CP VKDOC/CP VKDOF/CP

ISO-DIN

DUAL BLOCK

DIN8063, DIN2501

EN 558-1

U-PVC, PP-H, PVC-C, PVDF

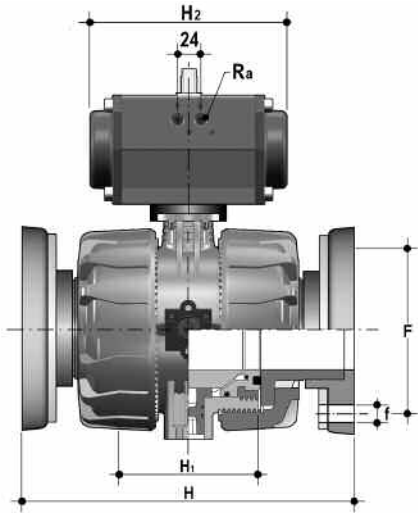

d	DN	PN	H	H ₁	H ₂		Ra	f	F
					(DA)	(SA)			
75	65	16	290	133	155	210	G1/4"	17	145
90	80	16	310	149	210	228	G1/4"	17	160
110	100	16	350	167	228	280,5	G1/4"	17	180

DN	g PVC-U		g PP-H		g PVC-C		g PVDF	
	(DA)	(SA)	(DA)	(SA)	(DA)	(SA)	(DA)	(SA)
65	7630	9400	5520	7290	8257	10027	9608	11378
80	11650	13580	8775	10705	12535	14465	14442	16372
100	17335	19955	12610	15230	18646	21266	21469	24089

* PP-H PN 10 bar

VKDOV/CP VKDOM/CP VKDOC/CP VKDOF/CP

ANSI

DUAL BLOCK

ANSI 150 #FF

EN 558-1

U-PVC, PP-H, PVC-C, PVDF

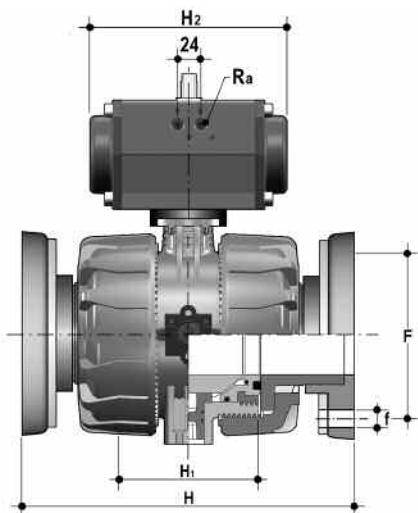

d	DN	PN	H	H ₁	H ₂		Ra	f	F
					(DA)	(SA)			
2" 1/2	65	16	290	133	210	210	G1/4"	18	139,7
3"	80	16	310	149	210	228	G1/4"	18	152,4
4"	100	16	350	167	228	280,5	G1/4"	18	190,5

DN	g PVC-U		g PP-H		g PVC-C		g PVDF	
	(DA)	(SA)	(DA)	(SA)	(DA)	(SA)	(DA)	(SA)
65	7630	9400	5520	7290	8257	10027	9608	11378
80	11650	13580	8775	10705	12535	14465	14442	16372
100	17335	19955	12610	15230	18646	21266	21469	24089

* PP-H PN 10 bar

CVDE-CVDM

PE

SDR 11 PN 16

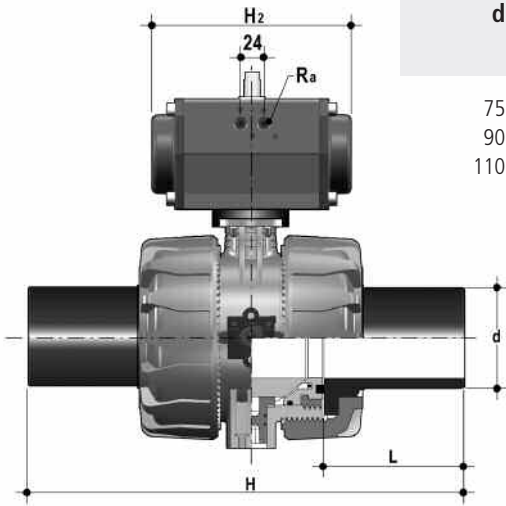

d	DN	*PN	L	H	H ₂		Ra
					(DA)	(SA)	
75	65	16	110,5	356	210	210	1/4"
90	80	16	118,8	390	210	228	1/4"
110	100	16	130,7	431	228	280,5	1/4"

* PP-H PN 10 bar

VKD

« »

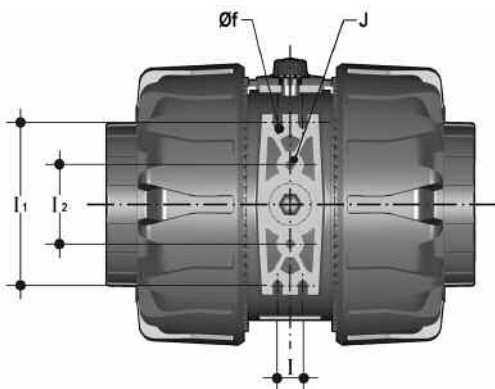

d	DN	J	f	l	l_1	l_2
75	65	M6	6,3	17,4	90	51,8
90	80	M8	8,4	21,2	112,6	63
110	100	M8	8,4	21,2	137	67

: 5

:

()

DA -

« »
« »

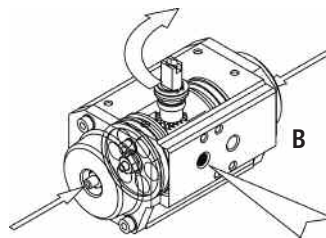
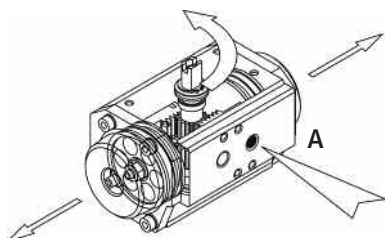

SA -

(NC -

, NO -

« »

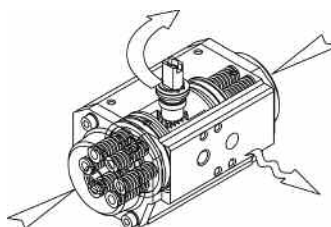
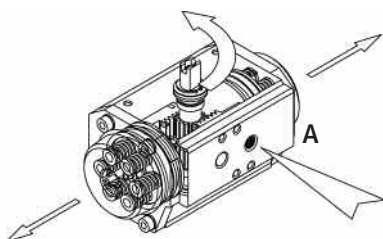

d	75	90	110
DN	65	80	100
DA	0,45NL	0,61NL	0,98NL
SA	0,61NL	0,98NL	1,8NL

3MS

(.1)

 : 250 - 16
 : IP65

 : -20° - +70°
 : 20 1,5

 - : PNP (3) (.2)
 : 10-30

 : IP65
 : IP67
 : -20° - +80°
 : 20 1,5

 - : NAMUR (.3)
 : 8

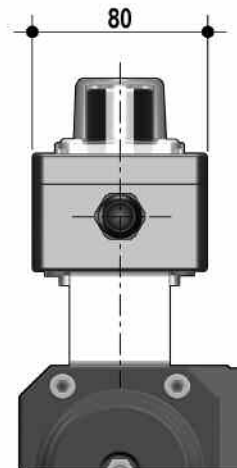
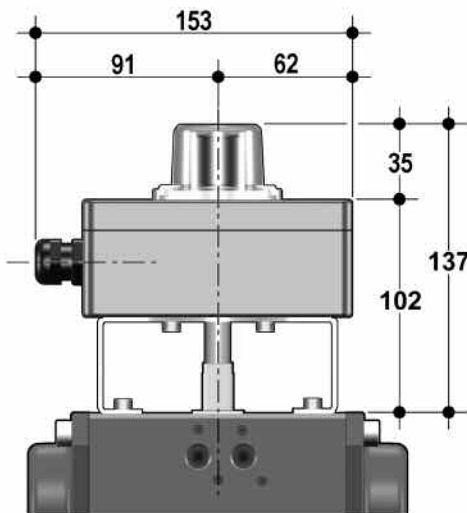
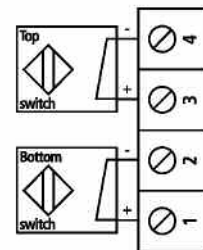
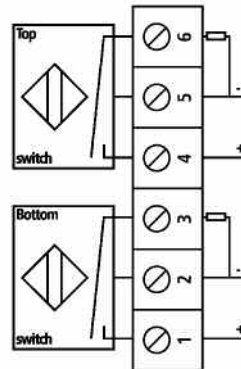
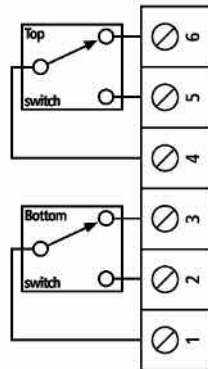
 : 1-3
 : IP65
 : IP67
 : -20° - +100°
 : 20 1,5

2EV

() 3-5/2

:
24, 48, 110, 230
12, 24
: IP65

: G 1/4"

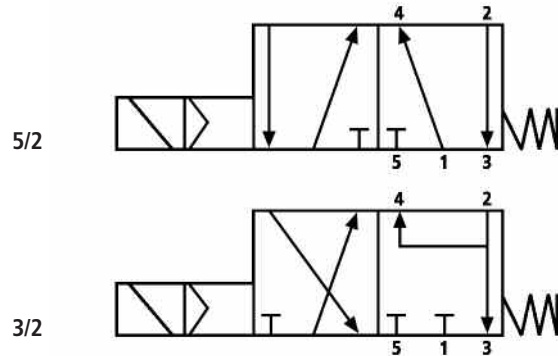

3PG

3-15 psi 4-20
: IP65
: -10° - +50°
: 400 / : G 1/4"



- 1.
2. (12) () (13)
- 3.
- 4.

(27)



DUAL BLOCK®

2 2

NaClO.

1. ,
2. , (27)
3. (13)
4. ,
5. (1) (3) (4)
6. (2)
7. (11) (22) (7)
- 8.
9. (17) (6) (16).
10. (20),
11. (21). (19).



- 1.
- 2.
- 3. PTFE (5)
- 4. (6).
- 5. (16)
- 6. (22)
- (15) (14).
- 7. (2).
- 8. (3) (4)
- 9. (12)
- (10).
- 10. (27).

(19),

(20-21)

(7)

(16).

(11),

(1).

(13)

(27).

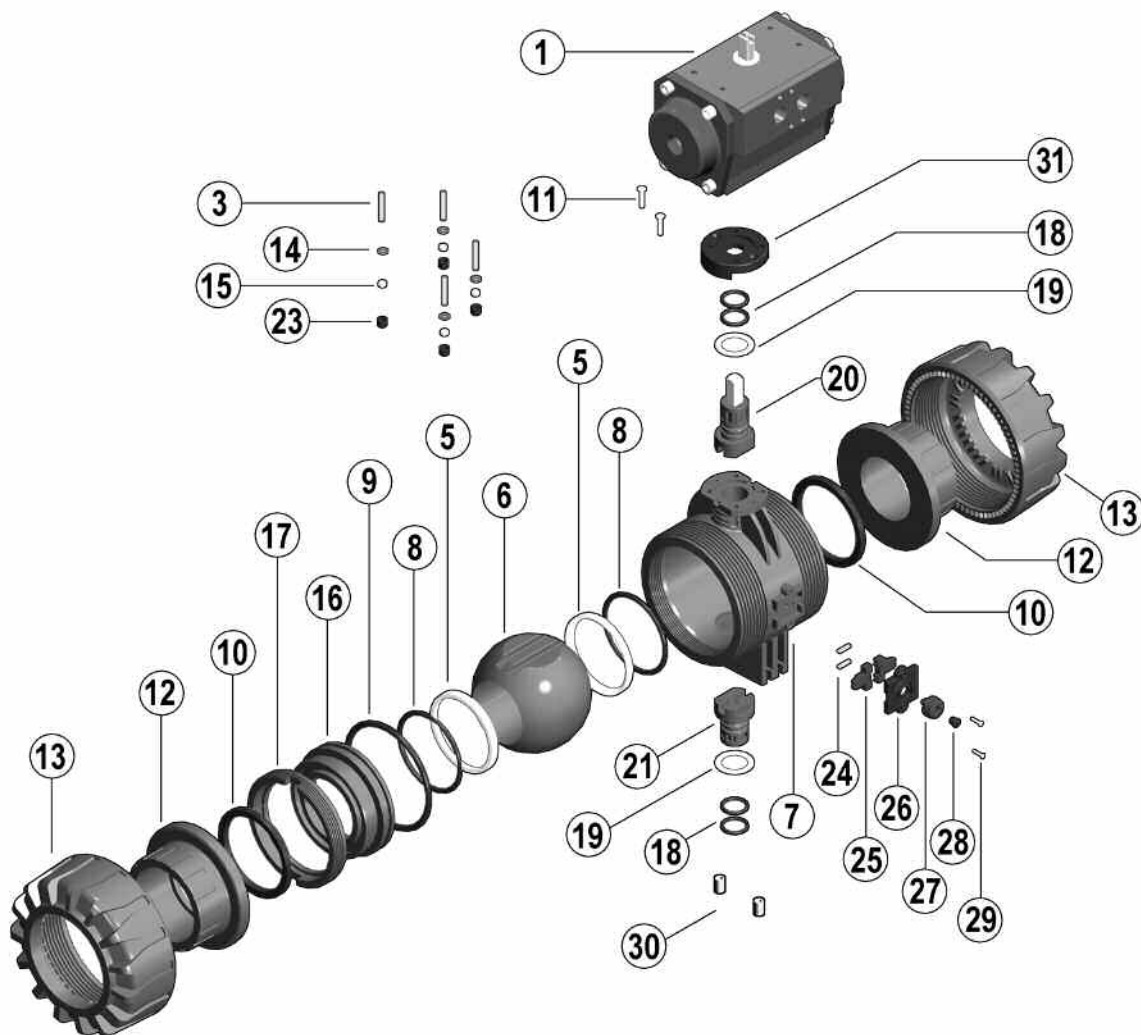

.			
1			1
3			1
5		PTFE	2
6		U-PVC /PP/C-PVC/PVDF	1
7		U-PVC /PP/C-PVC/PVDF	1
8		EPDM FPM	2
9		EPDM FPM	1
10		EPDM FPM	2
11			2
12		U-PVC /PP/C-PVC/PVDF	2
13		U-PVC /PP/C-PVC/PVDF	2
14			2
15			2
16		U-PVC /PP/C-PVC/PVDF	1
17		U-PVC /PP/C-PVC/PVDF	1
18		EPDM FPM	4
19		PTFE	2
20		U-PVC /PP/C-PVC/PVDF -	1
21		U-PVC /PP/C-PVC/PVDF	1
22		PP-GR	1
23		PE	2
24			2
25		PP-GR	2
26		PP	1
27		PP-GR	1
28		PE	1
29			2
30			2
31		PP-GR	1

*

**